

Możliwe schematy otwierania do wewnątrz oraz linie przekrojów:

2-2-0

3-3-0

4-4-0

5-5-0

6-6-0

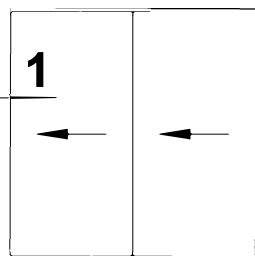

3-2-1

3-1-2

4-3-1

5-4-1

6-5-1

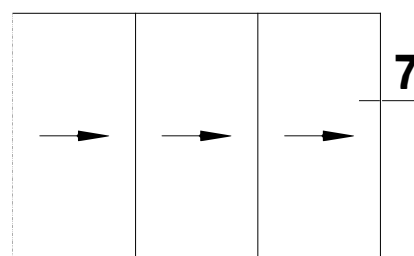
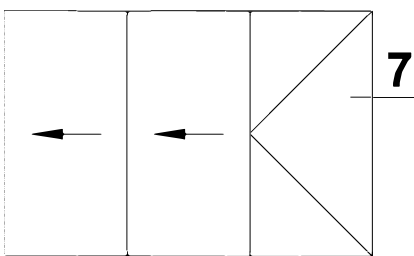

2-2-0

4-4-0

6-6-0

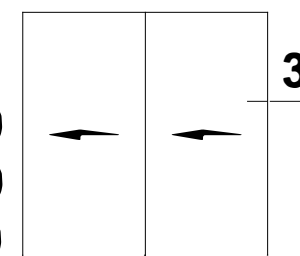

2-2-0

3-3-0

4-4-0

5-5-0

6-6-0

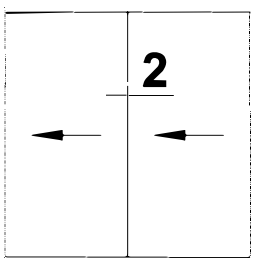

3-3-0

4-4-0

5-5-0

6-6-0

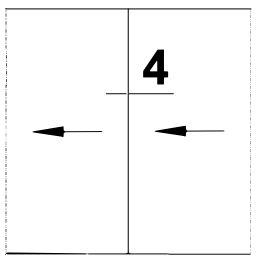

3-3-0

5-5-0

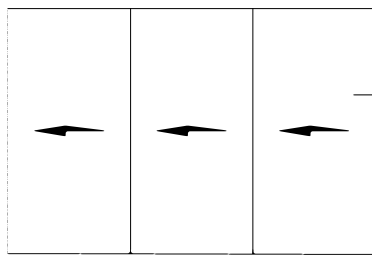

3-2-1

5-4-1

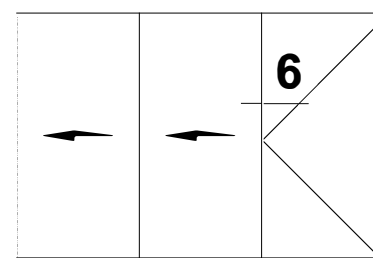

3-1-2

5-3-2

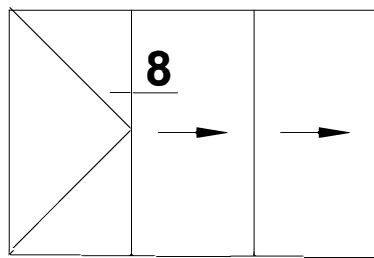

4-3-1

6-5-1

6-3-3

4-1-3

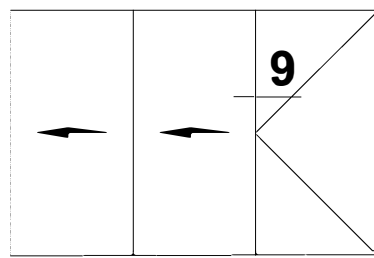

10

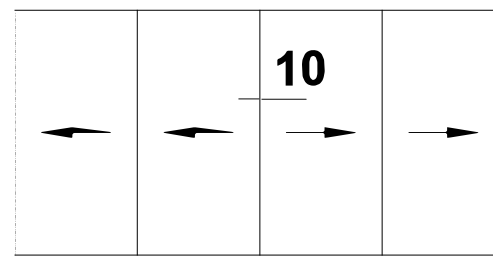

4-2-2

6-4-2

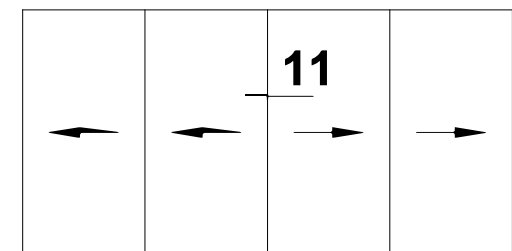

DAKO • Dział Rozwoju Produktu opracował: Stanisław Frączek	02/2019	K.P.AL.DA-77 FD str.1	Rzut	skala 1:10
	DA-77 FD HD			Przekroje

The copyright to all of our drawings remains with our company. They may not be copied, nor made accessible to third parties without our express written permission. All drawings and possible static calculations must be checked. No legal claims are possible from their use.

Możliwe schematy otwierania na zewnątrz oraz linie przekrojów:

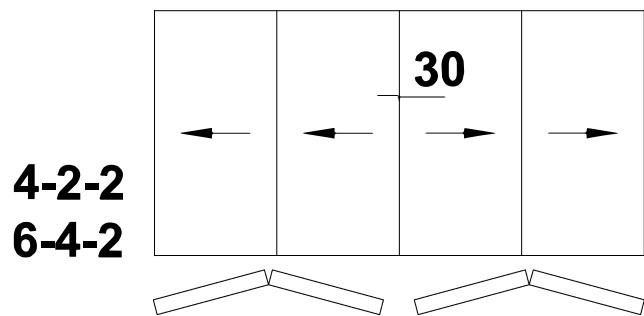
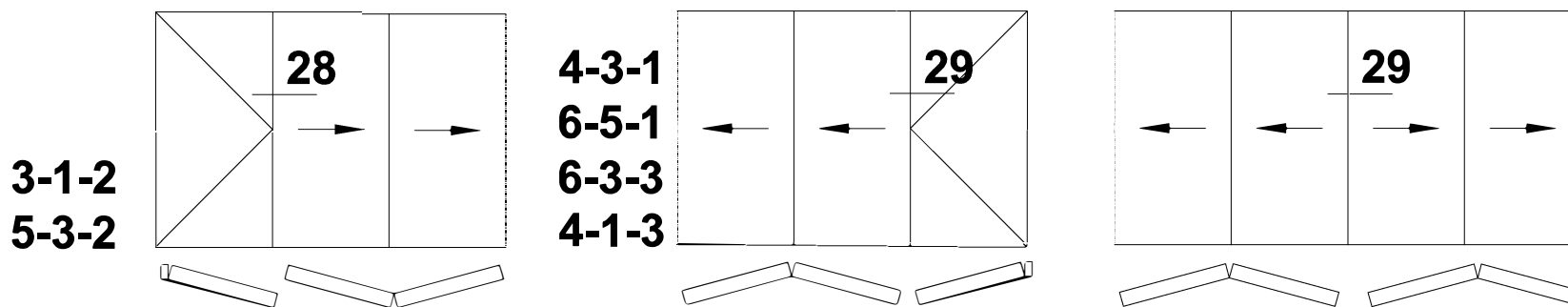
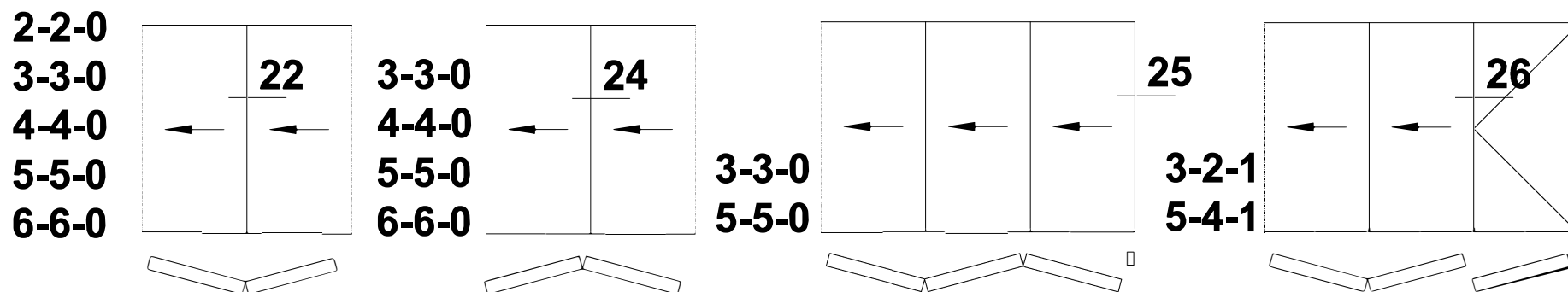
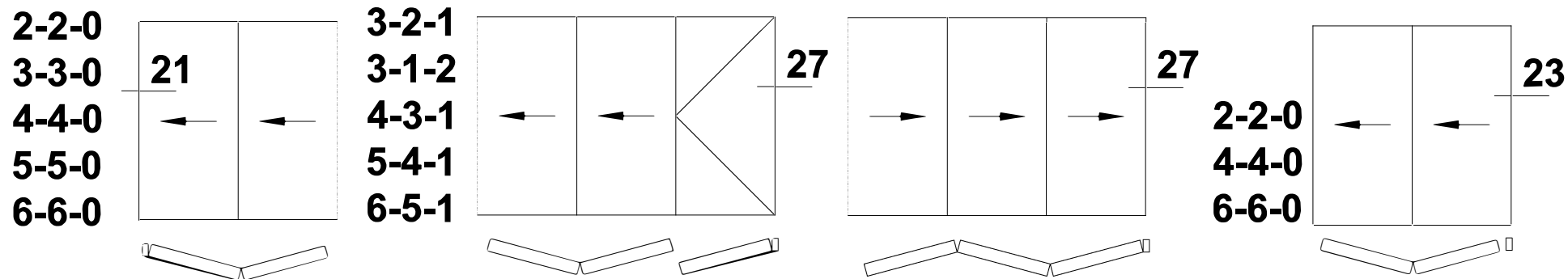

DAKO • Dział Rozwoju Produktu opracował: Stanisław Frączek 02/2019 K.P.:AL.DA-77 FD str.2	Rzut	skala 1:10
	Przekroje	skala 1:1

The copyright to all of our drawings remains with our company. They may not be copied, nor made accessible to third parties without our express written permission. All drawings and possible static calculations must be checked. No legal claims are possible from their use.

Możliwe schematy otwierania do wewnątrz lub na zewnątrz oraz linie przekrojów:

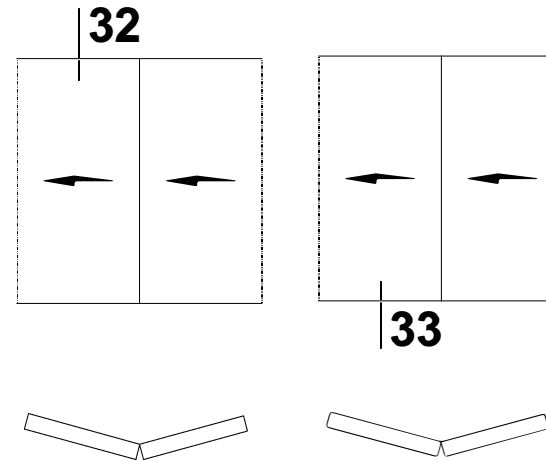
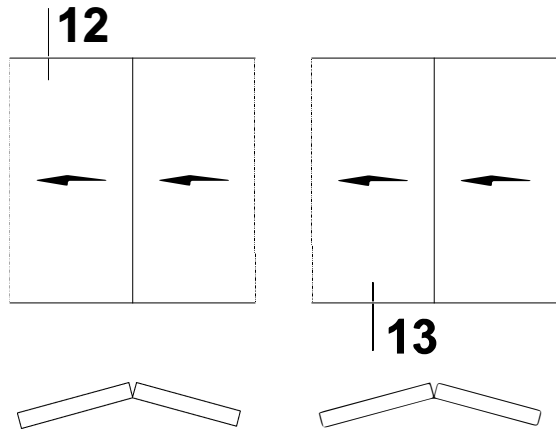

Możliwe schematy otwierania do wewnątrz lub na zewnątrz oraz linie przekrojów:

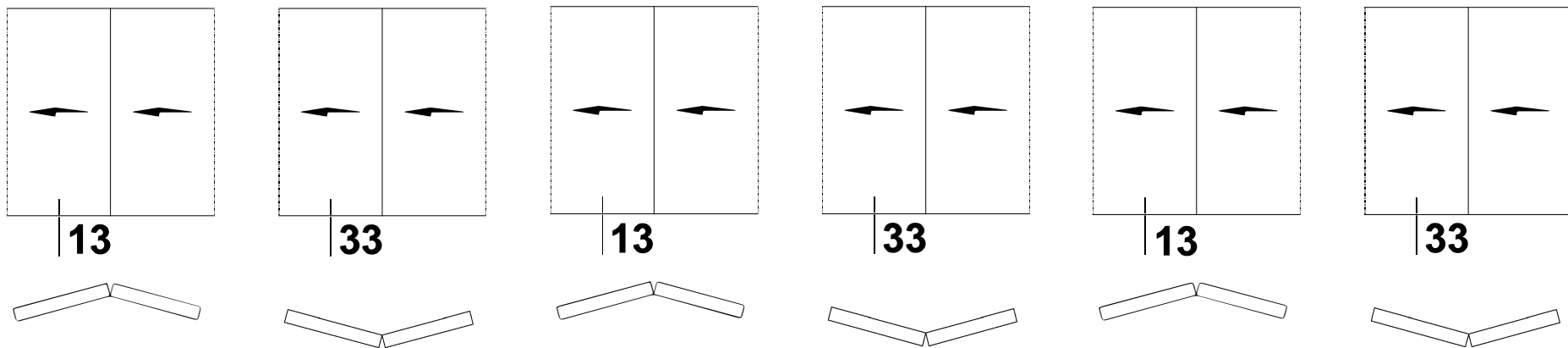

DAKO • Dział Rozwoju Produktu opracował: Stanisław Frączek 02/2019 K.P.AL.DA-77 FD str.3	Rzut	skala 1:10
	Przekroje	skala 1:1
DA-77 FD HD		
The copyright to all of our drawings remains with our company. They may not be copied, nor made accessible to third parties without our express written permission. All drawings and possible static calculations must be checked. No legal claims are possible from their use.		

Przekroje:

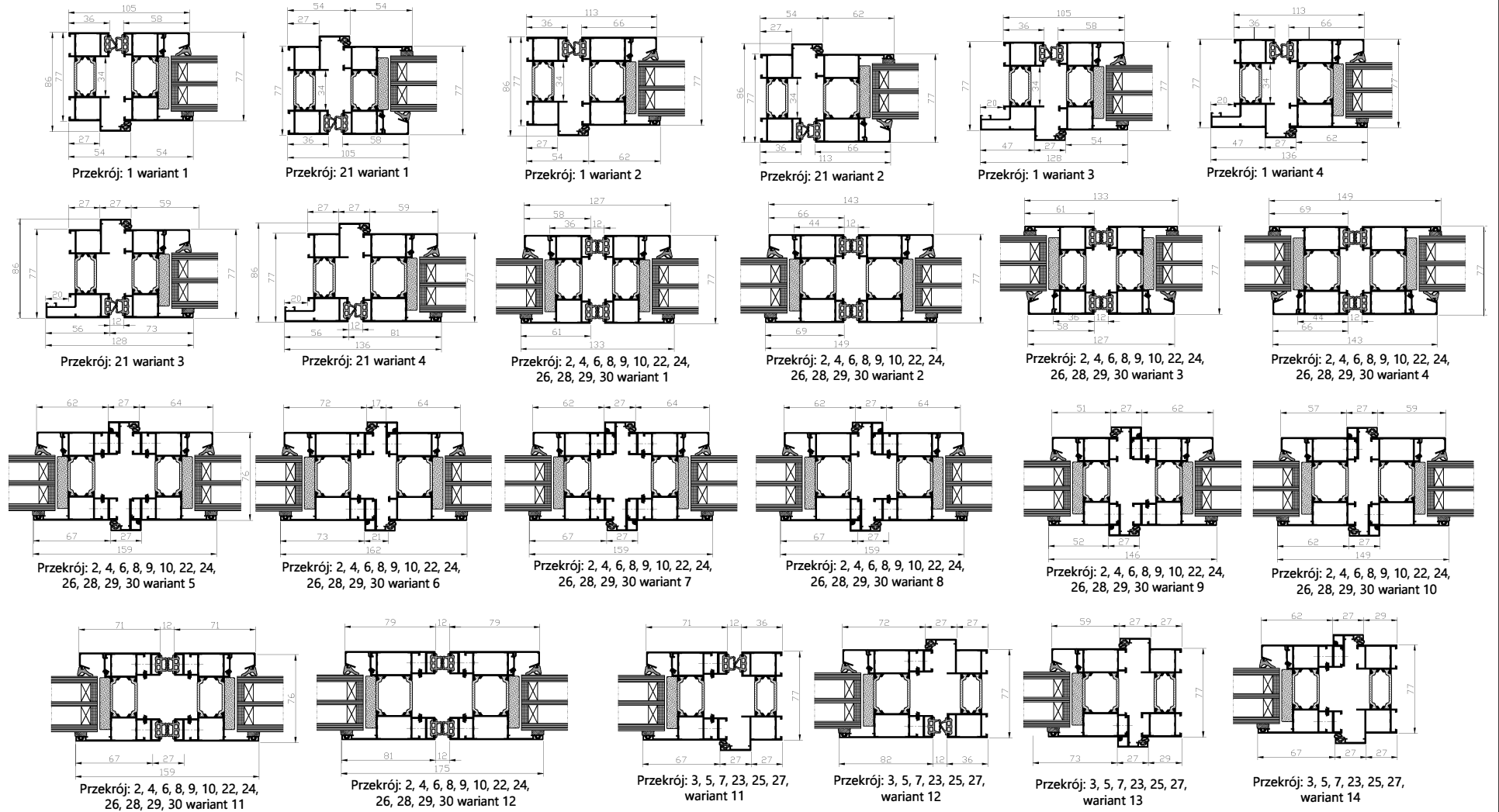

DAKO • Dział Rozwoju Produktu opracował: Stanisław Frączek 02/2019 K.P.AL.DA-77 FD str.4	Rzut	skala 1:10
	Przekroje	skala 1:1

DA-77 FD HD

The copyright to all of our drawings remains with our company. They may not be copied, nor made accessible to third parties without our express written permission. All drawings and possible static calculations must be checked. No legal claims are possible from their use.

Przekroje:

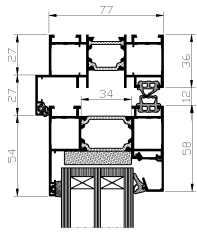

Przekrój: 12, 32 wariant 1

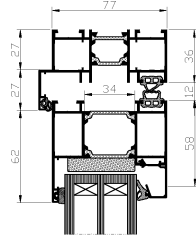

Przekrój: 12, 32 wariant 2

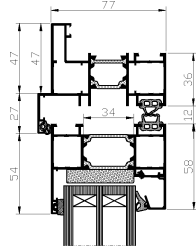

Przekrój: 12, 32 wariant 3

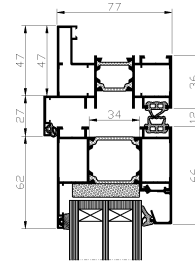

Przekrój: 12, 32 wariant 4

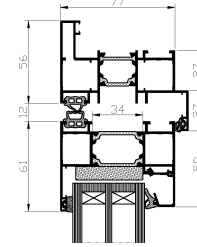

Przekrój: 12, 32 wariant 5

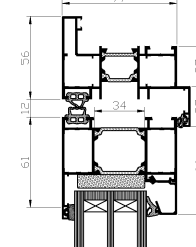

Przekrój: 12, 32 wariant 6

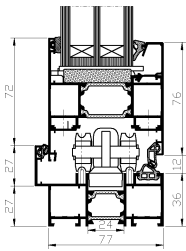

Przekrój: 13, 33 wariant 1

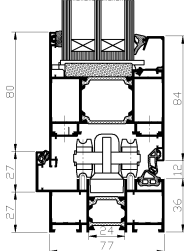

Przekrój: 13, 33 wariant 2

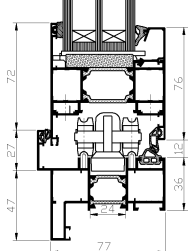

Przekrój: 13, 33 wariant 3

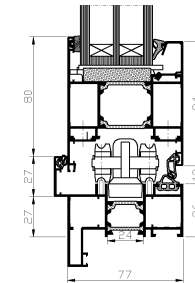

Przekrój: 13, 33 wariant 4

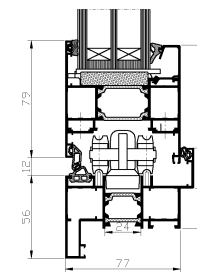

Przekrój: 13, 33 wariant 5

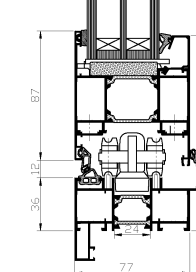

Przekrój: 13, 33 wariant 6

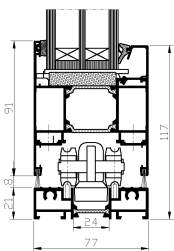

Przekrój: 13, 33 wariant 7

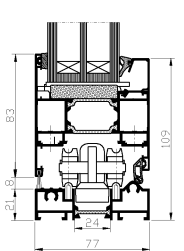

Przekrój: 13, 33 wariant 8

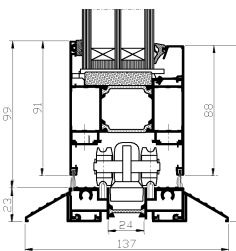

Przekrój: 13, 33 wariant 9

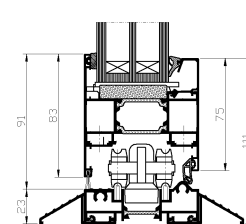

Przekrój: 13, 33 wariant 10

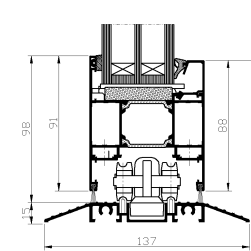

Przekrój: 13, 33 wariant 11

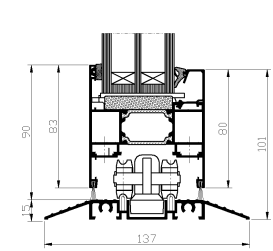

Przekrój: 13, 33 wariant 12

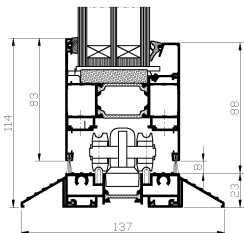

Przekrój: 13, 33 wariant 13

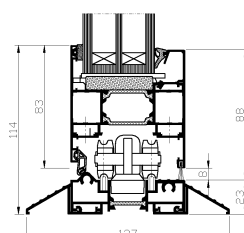

Przekrój: 13, 33 wariant 14

DAKO • Dział Rozwoju Produktu
opracował: Stanisław Frączek 02/2019 K.P.AL.DA-77 FD str.5

DA-77 FD HD

Rzut

skala 1:10

Przekroje

skala 1:1

The copyright to all of our drawings remains with our company. They may not be copied, nor made accessible to third parties without our express written permission. All drawings and possible static calculations must be checked. No legal claims are possible from their use.

Przykłady zabudowy

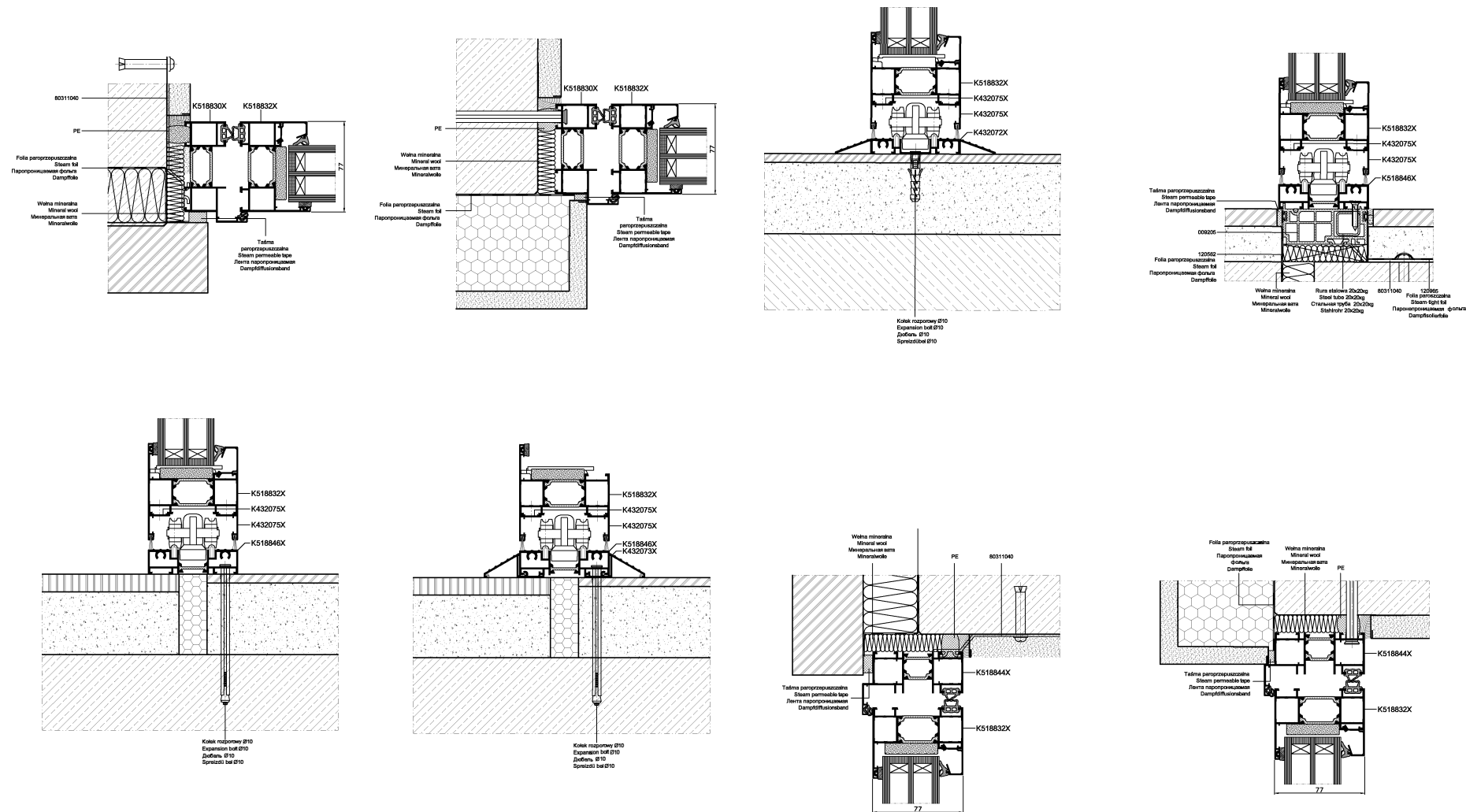

DAKO	Dział Rozwoju Produktu opracował: Stanisław Frączek	02/2019	K.P.AL.DA-77 FD str.6	Rzut	skala 1:10
	DA-77 FD HD			Przekroje	skala 1:1

The copyright to all of our drawings remains with our company. They may not be copied, nor made accessible to third parties without our express written permission. All drawings and possible static calculations must be checked. No legal claims are possible from their use.