

Wooden window System DDF-92

1-sash (reference)

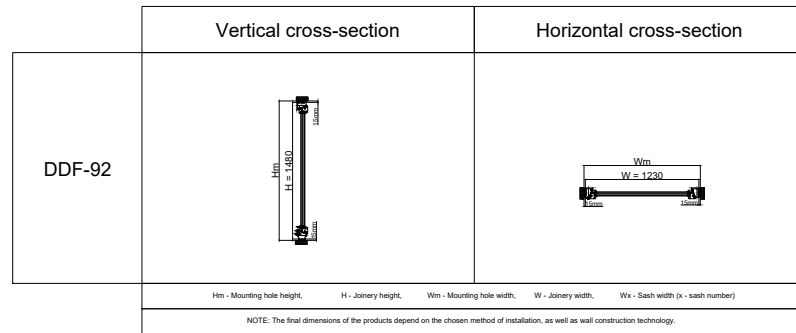

Wooden window System DDF

- Window finish with a modern, simple form, in line with current trends
- Thermal and acoustic insulation parameters in accordance with building standards given in the table below
- Highest comfort of use
- Variants of wood type: pine, meranti

Prestigious series of DAKO wooden windows DDF, taking full advantage of the extraordinary value of carefully selected natural raw material. The simple form of the profile shape gives the windows a modern character and perfectly fits into the trends of minimalist architecture. The advanced technology used in the production of the window has won the recognition of customers, confirmed by awards from industry experts.

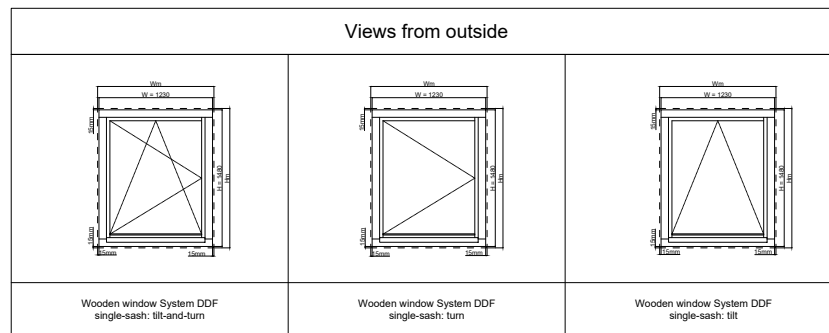

Parameters of wooden reference window (single-sash window 1230x1480mm)									
System	Glazing package	Uw	Ug	TET (g)	LT	Resistance to wind load	Waterproofing	Air permeability	Rw
DDF-68	4x16x4	1,3	1	0,5	0,68	NPD	7A	4	33dB
DDF-78	4x14x4x14x4	0,95	0,6	0,53	0,74	NPD	E900	4	34dB
DDF-92	4x16x4x16x4	0,83	0,5	0,38	0,59	NPD	5A	4	34dB

Uw - heat transfer coefficient of the window, Ug - heat transfer coefficient of the glazing package, TET(g) - solar energy transmittance, LT - light transmission, Rw - acoustic properties